

CAPACITORS SUPPORT RADAR MMIC AMPLIFIERS VIA BYPASSING

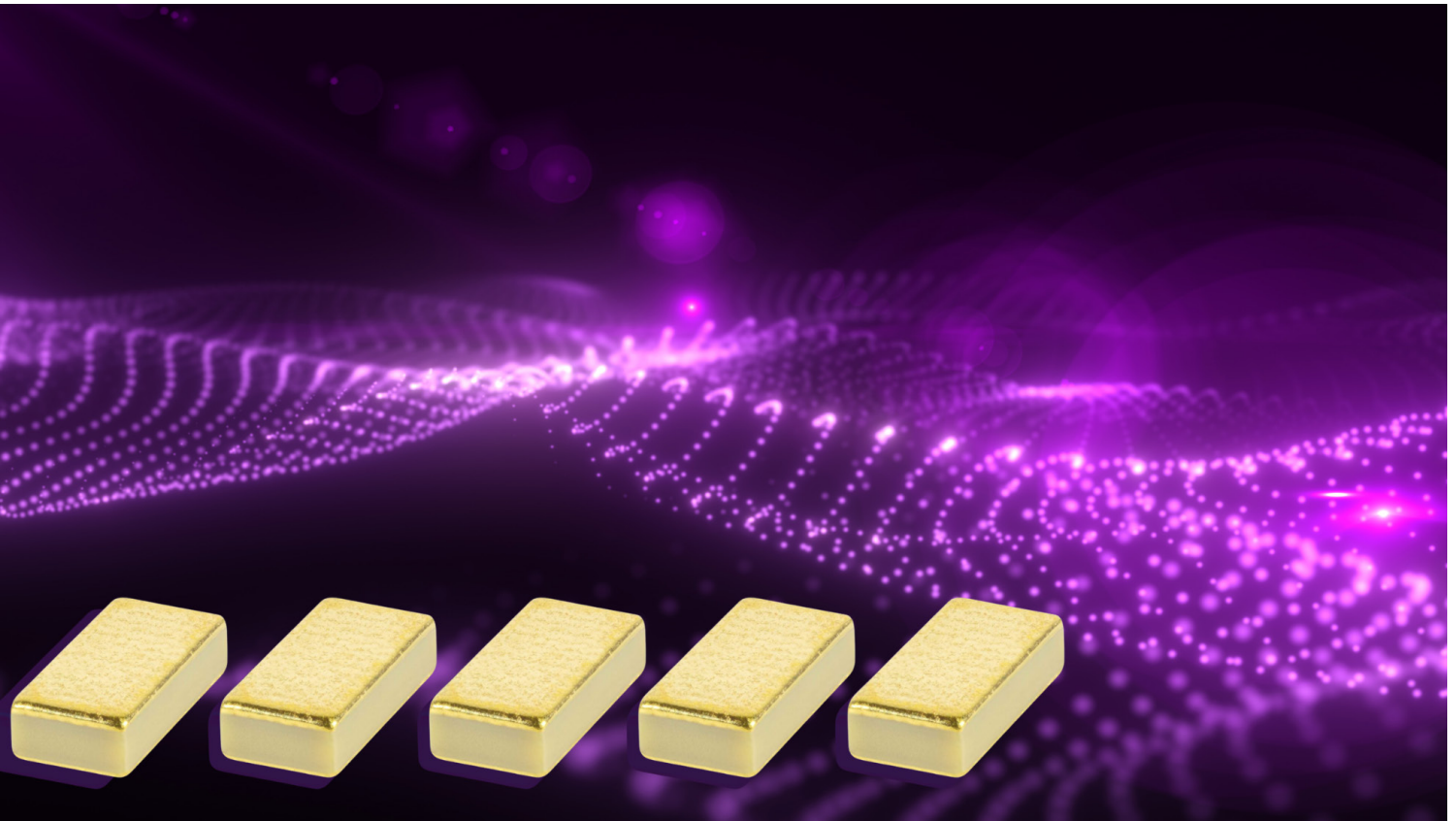

Monolithic microwave integrated circuit (MMIC) amplifiers are widely used in defense radar systems. The industry recognizes them as a compact, high-performance option that's reliable and easy to integrate. Whether they serve a receive (e.g., low noise amplifier (LNA)) or transmit (e.g., power amplifier (PA)) function, MMIC amplifiers rely on bypass capacitors to perform their core function to amplify microwave signals.

When placed in parallel with the signal path, [capacitors serve a bypassing function](#). They allow direct current (DC) to continue along the wire, but they divert high-frequency signal components to ground (i.e., shunt to ground). In other words, capacitors act as low-pass filters that prevent radio frequency (RF) noise from feeding back to the amplifier and minimize interference by decoupling the circuit and the supply.

A range of frequencies must be removed from DC lines, so naturally, there's a range of capacitor values to accommodate that. For example, Figure 1 shows a PA gate and drain bias circuit leveraging three different bypass capacitor values.

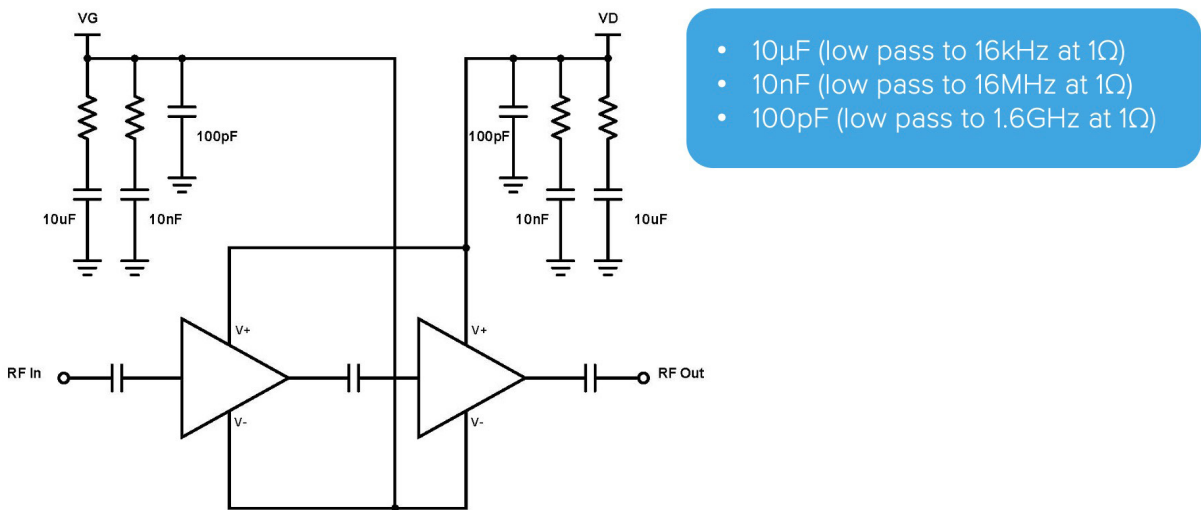

Figure 1. Example of a power amplifier's gate and drain bias circuit transistor configuration

Larger capacitance values typically serve in low-frequency filtering applications and smaller capacitance values are best for RF applications; however, certain bypass capacitors support a wide range of frequencies and device technologies.

Many capacitor types, from electrolytic to ceramic NPO, can function in a bypassing capacity, so your selections depend on your system's frequency response and stability requirements. Aside from observing the general rule of thumb that the impedance of your bypass capacitor should be valued at 10 percent of the impedance of the relevant circuit element, consider factors like insulation resistance (IR), equivalent series inductance (ESL) and equivalent series resistance (ESR).

KNOWLES PRECISION DEVICES

Single-layer bypass capacitors (SLCs) can support a wide range of frequencies and bypassing close to MMIC chips. That proximity is critical for avoiding the stray inductance caused by a long trace. Knowles Precision Devices' single-layer vertical electrode capacitor series ([V Series](#)) includes a 100nF V80 bypass capacitor with an operating voltage of 50V in a .084" x .042" package.

[See the full specifications and dimensions](#) for our V80 SLCs or [get some advice](#) on properly selecting a capacitor for MMIC RF bypassing.

Contact Us

If you need help selecting from our portfolio please contact us and we can guide you through the selection process.



2777 Hwy 20
Cazenovia, NY 13035



(315) 655-8710



Contact Knowles