



Have You Considered
Everything in the Design
of Your EMI Filter?



TABLE OF CONTENTS

Introduction	2
What Tests Should Be Considered?	2
Insertion Loss/Attenuation	2
Compatibility	3
Reliability	4
Final Thoughts	4
References	5
<i>Please see last page for Schaffner USA Contact Information</i>	6

INTRODUCTION

With the growing popularity of electronic devices, the demand for regulation has created a vast array of standards and conformity procedures. Regulatory agency requirements dictate that not only conducted and radiated emissions be constrained below specified limits, but that the unit must also pass immunity/transient requirements as well. Accompanying this is the need not only for testing but for improvements to equipment design.

Unfortunately, EMC is typically the last step in a design. When all the other product features have been implemented and the functionality is established, any EMC problems are then solved. At this point, EMC becomes expensive, time-consuming and difficult to handle. Manufacturers should therefore always start thinking about EMC in the early stages of product design. This thought process pertains to the EMI power input filter as well. Designers often

forget that an EMI filter can assist in meeting immunity and fast transients requirements along with radiated emissions as well. Even for military/aerospace equipment, they must be protected from failure due to EMI noise and security requirements may call for filters to protect classified data.

Generally, the power line or mains EMI filter is placed at the power entry point of the equipment that it is being installed in to prevent noise from exiting or entering the equipment. Most of the time, only the attenuation or insertion loss, rated current, rated voltage, and regulatory approval requirements are specified by the user. However, there are many other parameters that should be or must be considered to get the most efficiency, reliability, and proper operation from the filter. The intent of this article is to present what some of those other important filter parameters are, and should be considered.

What Tests Should Be Considered?

1. INSERTION LOSS/ATTENUATION

a. Stopband – Common Mode/Different Mode

Filters are typically characterized by their insertion loss (IL), which is expressed in dB's. The insertion loss is a measure of the load reduction at the given frequency due to the insertion of the filter. It is very important to note that the insertion loss of a filter is dependent on the source and load impedances, and thus cannot be stated independently of the terminal load/source impedances. Despite this fact, filter manufacturers often list an insertion loss value on a filter's data sheet without specifying these impedance values.

A common mistake is to use a filter solely based upon the standard 50 Ohm input/50 Ohm output insertion loss that is typically published by the filter manufacturer's catalog data per MIL-STD-220. When this occurs, it can be misleading, because for that particular filter to work properly with your device, the input impedance seen looking into the power cord of your device must be 50 Ω . Since this is a rather unrealistic design constraint to place on a product, it is unlikely that the use of such a filter on your product will result in the filtering results specified by the manufacturer's insertion loss data. This is why the selected filter must still be tested in the actual system to verify results.

Filters should not be expected to provide voltage regulation, clamping or smoothing. The value of inductive reactance should be kept small to prevent excessive distortion of the power frequency. The maximum value of line-to-line capacitance (differential mode) reactance should be no less than 100 times the filtered device's input impedance. These two simple rules will help avoid power frequency issues such as voltage drop or waveform distortion. Test the filter for both common mode and differential mode attenuation. Adequate differential mode and common mode filtering must fit the potential problem (see *Figure 1*). Remember that any filter schematic is only an approximation of the filter circuit especially at higher frequencies. In real life, the filter components exhibit tolerance, saturation, and parasitics as well as coupling.

b. Passband

To design a good filter, the passband must be defined just as the potential interference frequencies. The level of anticipated interference should be approximated. Comparing this to the required EMC standard will yield the degree of necessary insertion loss or attenuation.

Unless the design engineer has experience in filter designing, it is recommended that such assistance be called upon from a potential filter manufacturer like Schaffner EMC, Inc. EMI test laboratories can also provide many filter choices.

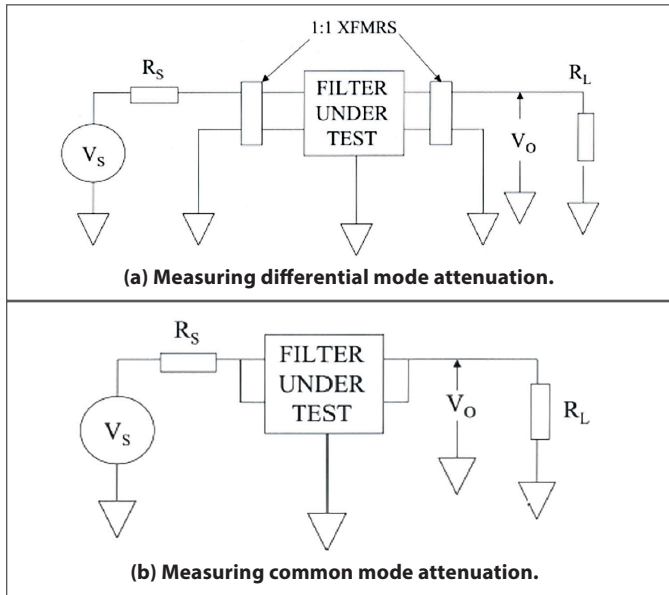

Figure 1. A Typical Test Setup for Measuring Filter Attenuation.

c. No Load/Full Load

The filter's insertion loss or attenuation characteristics should be verified not just at the "no load", but for the "full load" current levels as well. Since inductors are one of the key components in the filter, it is important to note that these are ideal and variables such as the type of core material and saturation current level through the inductor can affect the value of the choke. Using the smallest L value possible and keeping the inductor ESR small will help. For more information, see the Rated Current section below.

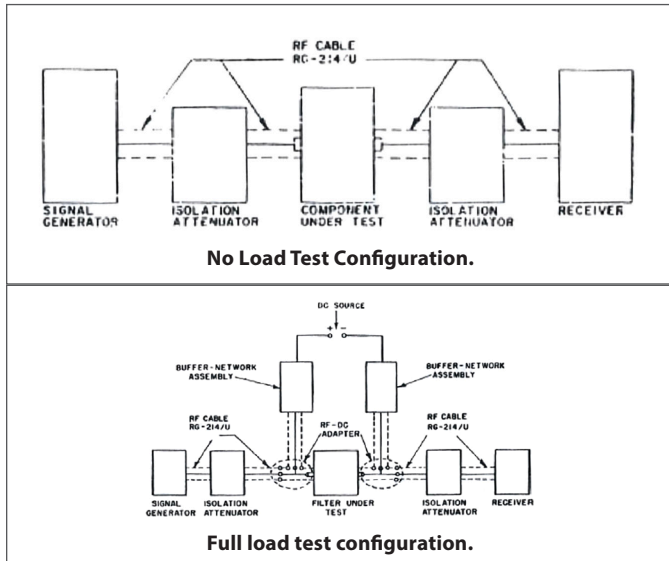

Figure 2. Typical Test Setup for no load/full load measurement.

2. COMPATIBILITY

a. Rated Current/ Current Overload/Leakage or Reactive Current

Rated Current – The rated current should be equal to the maximum input current to be drawn from the device being filtered. Chokes consist of an electrical conductor wound

around a material with magnetic characteristics, the core. The choke always makes use of its magnetic characteristics to suppress RF noise. The core material determines the performance of a choke. It enhances the magnetic effects in the choke, improves the suppression characteristics and leads to more compact components. Core materials are also dependent on outside factors such as temperature or current. When used outside of its specified current range, a choke can saturate, leaving it unable to supply its original impedance (see Figure 3).

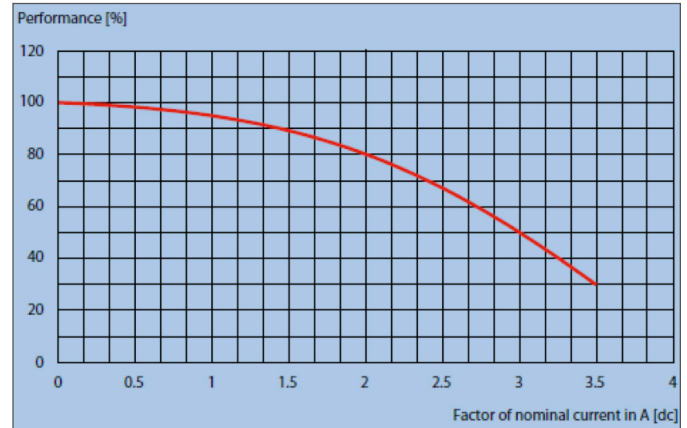

Figure 3. Saturation of a Typical Choke Due to Current.

Since current flow leads to a temperature rise in passive components, the ambient temperature of the environment where the filter is to be used has a direct impact on the rated current. The maximum operating current at any other ambient temperature can be calculated by means of the following formula:

$$I = I_N \cdot \sqrt{\frac{\theta_{max} - \theta_{act}}{\theta_{max} - \theta_N}}$$

Equation 1.

- where I_N rated current at θ_N
- θ_{act} is actual ambient temperature
- θ_N is temperature at which the rated current is defined
- θ_{max} is rated maximum temperature of the component

If a filter with $I_N = 7A$ at $\theta_N = 50^\circ C$ and a rated maximum temperature of $\theta_{max} = 100^\circ C$ is to be used at an ambient temperature of $\theta_{act} = 65^\circ C$, the rated current of this filter must be reduced to $I_{N,65^\circ C} = 5.9 A$.

Current Overload – Current overload characteristic of a filter demonstrates the filter's ability to withstand the heat dissipated by the filter's components when subjected to a higher than rated current of the filter. Typically, it is performed per paragraph 4.6.10 of MIL-F-15733 at 140% of the rated current under rated frequency for 15 minutes. After the required time period, insulation resistance and voltage drop (see Figures 4 and 6) must be repeated.

When the power is turned on, current begins to flow, and the initial current flow reaches a peak current value that is

larger than the steady-state current value. Following this, the current value gradually decreases until it stabilizes at the steady-state current. The part during which a large current flows before reaching the steady-state current is the inrush current. If the size of the inrush current exceeds that allowed by the part in use, depending on the magnitude of the inrush current (difference between the peak current value and the steady-state current value) and length of its duration (the length of time until the peak current value converges with the steady-state current value, hereafter called the pulse width), the part used in the circuit may overheat, potentially causing the electrical device to malfunction or break down.

Leakage Current – During normal operation of electrical equipment, some current flows to earth. Such currents, called leakage currents, pose a potential safety risk to the user and are therefore limited by most current product safety standards. Examples for these standards are EN 60950-1 for information technology equipment, IEC60601 for medical equipment or UL 1283 for passive EMI filters. The standards include limits for the maximum allowed leakage current. For passive EMI filters it is common to calculate the leakage currents based on the capacitor values against earth and other parasitic components. This leakage current is limited by the international safety agencies to prevent a danger to personal safety.

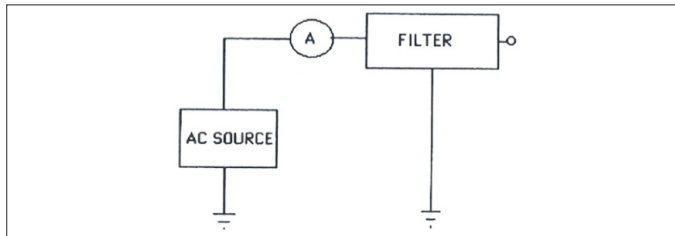

Figure 4. Leakage Current Test Circuit.

b. Rated Frequency

The frequency of the AC mains supply is either 50 or 60 Hz. The operating frequency of the filter is determined by the behavior of the capacitors. Depending on the voltage/frequency characteristic of the capacitor, it might be possible to operate a filter at a higher frequency but with a reduced input voltage.

c. Rated Voltage/Voltage Drop/Overshoots

Rated Voltage – The rating voltage should be equal to or greater than the maximum input voltage to be supplied to the device being filtered. The rated voltage of the filter defines the maximum continuous operating voltage, i.e., the maximum voltage at which the filter should be used continuously. Short overvoltages are permitted in accordance with IEC 60939, but to avoid damage to the filter capacitors, the continuous voltage should not exceed the rated voltage for an extended period of time.

Voltage Drop – The impedance of the filter is measured at

the relevant power network frequency, i.e., 50 Hz for European applications and 60 Hz for North American applications. This is performed at a defined temperature, such as 25°C. Current flowing through this impedance, of course, will cause a voltage drop across the filter resulting in a change in the voltage seen at the load end of the filter.

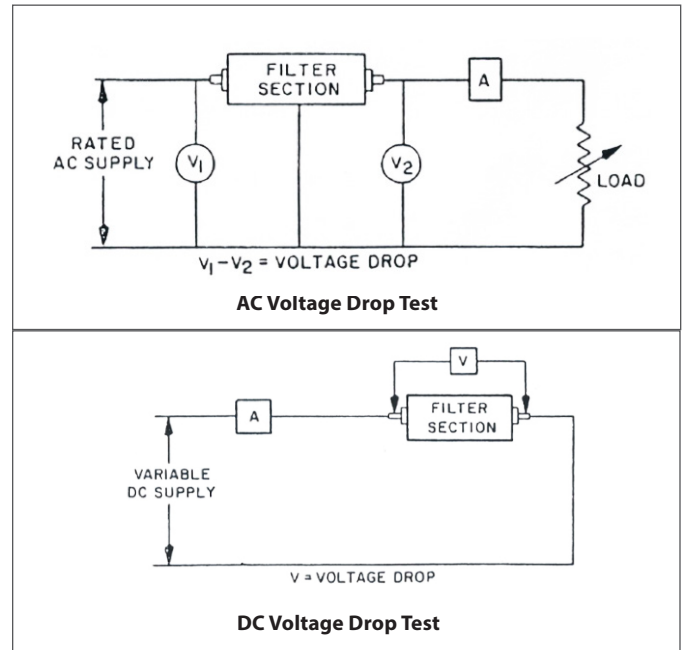

Figure 4. Typical Voltage Drop Test Configuration.

Overshoots – Voltage overshoots and voltage peaks can come with high dv/dt values but are also a problem on their own. The inductance of the filter acts like a choke according to the energy storage principle. If chokes are subject to voltage pulses, voltage peaks occur every time switching on or off takes place. The higher the energy content (inductance) of the choke, the higher these voltage peaks become. These amplitudes can, in turn, reach values that cause a stress situation in the winding insulation.

d. Harmonic Distortion/Instability

The LC filter can also act as a series resonant circuit across any power converter terminals and can affect the stability of the converter if the filter is under damped and the filter's resonant frequency is inside or close to the control loop bandwidth. It can appear deceptively easy to design filters. Unfortunately, many other factors must be considered as we mentioned in this article such as peak load current, saturation of inductors, elevated temperatures and output impedance. The output impedance of the filter can be a critical item when incorporated within switching power supplies. The negative input impedance of a switching power supply can oscillate in conjunction with the output impedance of the line filter. An important design criteria known as Middlebrook must be considered. The Middlebrook criteria states that the output impedance of the filter must be less than the reflected load impedance of the switching power supply.

If you have one filter following another in tandem, the designer may consider oscillation as a possibility. The filters can detune each other especially if all, or any, of the filters have a high circuit Q of 2 or higher. Typically, this oscillation moves the cut-off frequency into the bandpass region reducing the input voltage to where the equipment being powered may not function. Also, the increased cascaded total capacitance could cause higher line and harmonic currents possibly adding heat to the filter.

3. RELIABILITY

a. Dielectric Withstand (Hi-Pot)

Dielectric testing, sometimes referred to as Hi-Pot testing, demonstrates the ability of the filter capacitors to ensure higher than rated voltage. In filters, components are used that are connected between the phases of the supply network or between one phase and earth. It is therefore important to determine how well filters resist high voltages.

A dielectric withstand test is performed for this reason by applying a voltage between enclosure and phase or between two connectors for a defined time. The current flowing between the same points is measured. Current flow means that the insulation is broken; the equipment fails the test.

During approval procedures, the test is usually performed over a longer period (typically one minute) with a defined voltage. Many safety standards require the testing to be performed on 100% of all units, but to save time, a test with higher voltage but reduced time is accepted. It should be noted that repeated high-voltage testing can lead to a damage of the insulation. Please note that this test is a high-stress test for the capacitors inside the filter. Each additional test stresses the capacitors again and leads to a reduction of lifetime. Schaffner recommends keeping the number of tests to a minimum and never test the filters at higher than the indicated voltages.

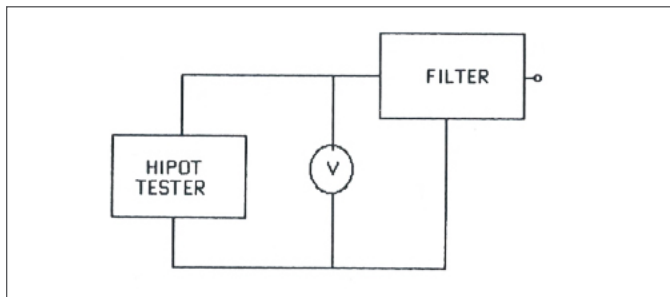

Figure 5. Typical Test Setup for Dielectric Withstand or Hi-Pot.

b. Insulation Resistance

Insulation resistance indicates quality of the filter capacitor construction and filter insulation system. Low insulation resistance may indicate a condition which may lead to possible deterioration over time. Sometimes this can be calculated from measurements of the DC leakage current at the specified voltage.

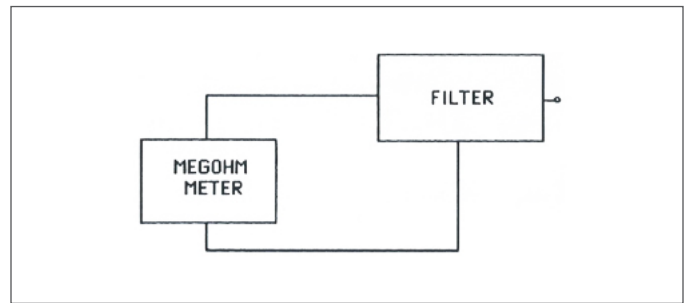

Figure 6. Setup for Insulation Resistance Test.

c. Temperature Rise

Temperature rise demonstrates that the filter remains at a cool temperature while operating at rated current and frequency. A “cool” filter will have a longer life. The test is performed at rated current and rated frequency and monitored until the filter reaches thermal equilibrium. The temperature rise is then calculated as the difference between the maximum stable case temperature minus the ambient temperature.

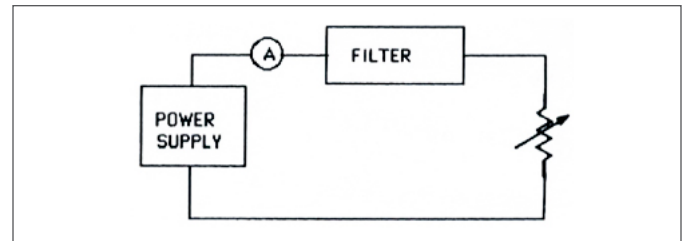

Figure 7. Temperature Rise Test Setup.

Some additional parameters to review while designing or considering an EMC filter include the type of capacitors to use, vibration, shock, climate classifications, environmental aspects and MTBF.

FINAL THOUGHTS

Schaffner not only can provide off the shelf EMC filter solutions but also support manufacturers with their EMC layout from the early stages of new product ideas or designs. Schaffner can also offer custom made solutions to help manufacturers meet any unique electrical, mechanical or EMC challenge. Contact your nearest Schaffner representative for assistance.

References

1. The EMC Desk Reference Encyclopedia, Don White, emf-emi control inc., Gainesville, VA, 1997.
2. Basics in EMC / EMI and Power Quality, Schaffner Group, Nordstrasse 11, 4542 Luterbach, Switzerland, 2013.

SCHAFFNER

shaping electrical power

SCHAFFNER EMC INC.

52 Mayfield Avenue
08837 Edison, New Jersey
+1 800 367 5566
+1 732 225 4789
usasales@schaffner.com
www.schaffnerusa.com

Product Types

Ecosine active
EMC/EMI
Power quality

Responsible For

USA
Brazil
Canada
Mexico

